



Seametrics

INSTRUCTIONS

AG2000 Irrigation Magmeter

FEATURES

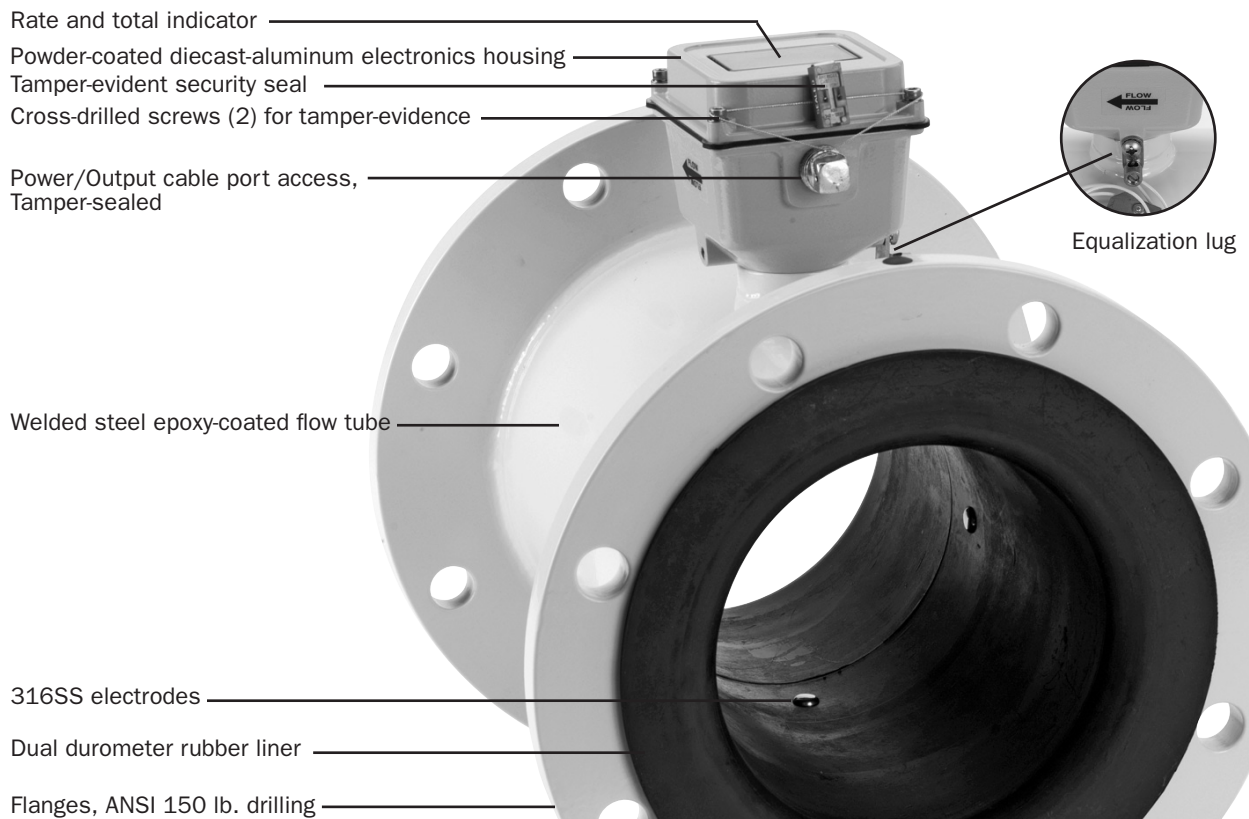

ISO 9001:2008
CERTIFIED

INSTALLATION

Tamper-Evident Seal. The battery-powered AG2000 has a seal wire to protect against unauthorized access. The seal can be broken to change units of measure, replace the battery pack, or to field-install a power/output cable (see page 4). **CAUTION:** If water usage regulation is in effect, only a person authorized by your regulatory agency should break the seal wire, and replace it when finished.

Positioning the Meter. These meters can be installed horizontally, vertically, and in any radial position. If sludge accumulation is possible, vertical or horizontal placement with the register at a 45° angle may be preferred.

Full Pipe Recommendations. All magmeters require a method for determining that the pipe is empty, to prevent false reading. This meter is designed to go to zero reading if one or more electrodes is exposed. For highest accuracy, install the meter so that the pipe will be full when there is flow. If air bubbles may be present in the pipe, rotate the meter by one flange hole to position the control housing at a 45° angle. See mounting diagrams below.

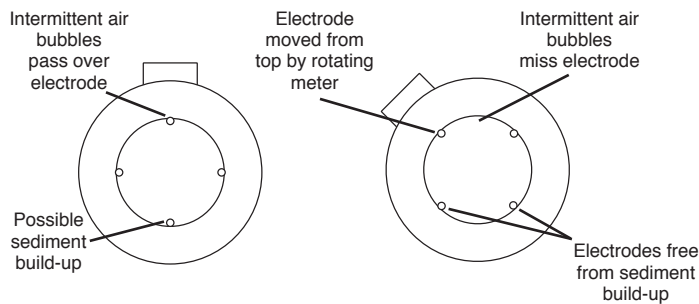

Possible Problem: Air bubbles and sediment on the electrodes can affect accuracy.

Better Installation: Improved accuracy results from unimpeded electrodes.

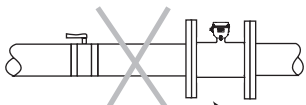

Possible Problem: Air pockets, accuracy loss, empty pipe reading

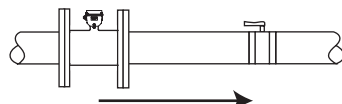

Better Installation: Keeps pipe full at sensor for accuracy

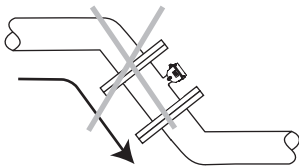

Possible Problem: Air can be trapped, loss of accuracy

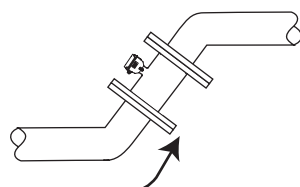

Better Installation: Allows air to bleed off, higher accuracy

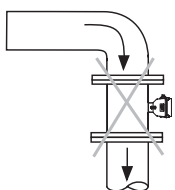

Not Recommended: Vertical downflow, open discharge

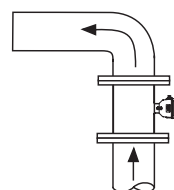

Better Installation: Vertical upflow with full pipe

Straight Pipe Recommendations. See the diagrams below for manufacturers' recommendations. NOTE: Local regulations may vary. Confirm before installing to assure compliance.

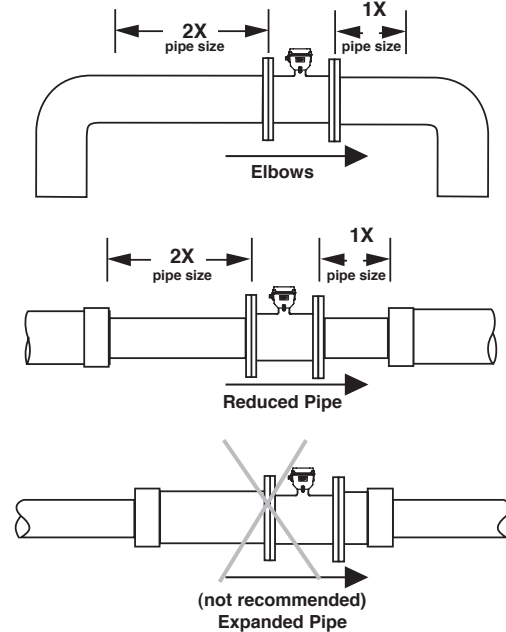

Chemigation Applications. Magmeters in chemigation applications must be placed either upstream of the chemical injection line, or far enough downstream for complete mixing to occur before the solution reaches the meter. Proper placement prevents spikes and drops in readings that result when fluids of different conductivity pass through the meter. For more information, refer to the technical bulletin on the Seametrics website Downloads page.

Fittings and Flanges. The AG2000 flanges have standard ANSI 150 lb. drilling, and should match up with any other ANSI 150 lb. flange. **IMPORTANT:** Piping protruding beyond welded-on flange faces may damage meter sealing surfaces.

Temperature. These flow sensors are recommended for operating temperatures of 10° to 130° F (-12° to 54° C) and non-operating temperatures of -40° to 158° F (-40° to 70° C).

Calibration. The AG2000 is factory calibrated and cannot be recalibrated in the field.

Protecting the Meter. A weather guard is recommended (Seametrics part #31388) for environmental protection.

Conductivity. The AG2000 requires media with >20 microSiemens of conductivity.

FLOW RANGE

	Minimum	Maximum
4"	12 gal/min (.75 liter/sec)	500 gal/min (31 liter/sec)
6"	32 gal/min (2 liter/sec)	1,200 gal/min (76 liter/sec)
8"	60 gal/min (4 liter/sec)	2,200 gal/min (139 liter/sec)
10"	95 gal/min (6 liter/sec)	3,500 gal/min (220 liter/sec)

EQUALIZATION and GROUNDING

Metal Pipe Installations. To equalize the electric potential of the fluid, the meter, and the surrounding pipe, secure the flange plates, factory-installed on equalization lug, to both pipe flanges at one of the bolt holes. Be sure the lockwasher provided fits between the pipe flange and the flange plate.

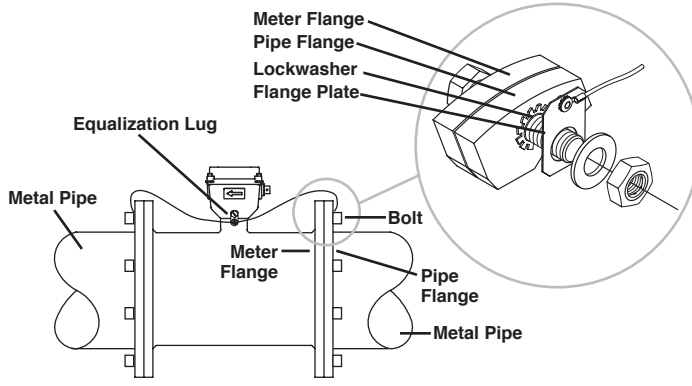

Equalization Diagram

Run wire from equalization lug to both pipe flanges; secure flange plates under bolt heads as shown.



WARNING: ELECTRICAL SHOCK HAZARD

When the AG2000 is installed in a plastic piping system, or when externally powered, it is very important to ground the meter to avoid electrical shock hazard. Failure to do so can result in electrocution.

Plastic Pipe Installations. In plastic pipe it is not necessary to use the equalization straps, but the meter must be grounded to avoid electrical shock and electrostatic interference with meter function.

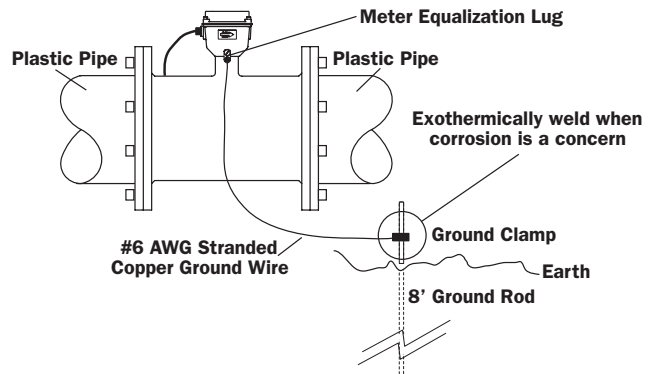

Battery Power (standard). The AG2000 is powered by a non-rechargeable battery pack with a lifespan of up to 5 years under typical use. Actual lifespan will vary from application to application, depending on the duty cycle.

“Low Batt” will display when it is time to replace the battery (see illustration at right). Replacement instructions come with the custom battery pack available from your dealer or Seametrics.

NOTE: Memory will not be lost during a battery change.

External Power (optional). Where power is available, the life of the battery pack can be indefinitely extended by the addition of an external power input cable. When external power is used, the batteries serve as backup in case of power failure, keeping the meter reading out during an outage. The display reads “P” to indicate that external power is in use (see illustration at right).

When the display is reading numbers/letters but neither the “Low Batt” or “P” symbol is displayed, the meter is functioning normally under battery power (see illustration at right). When the display is completely blank, the meter is not powered.

Solar Power (optional). In most areas of the US, a 12-volt, 5 watt solar power unit (panel, charge controller and battery) should suffice to operate the meter. In this case, the internal batteries will serve as backup and battery life will be conserved.

Display Reading. There are two lines to the display, the bottom line for flow rate and the top line for accumulated total. Measurement units are pre-ordered and factory-set and can be changed in the field only by an authorized individual.

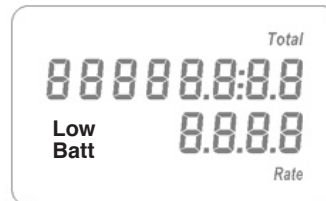

Low Battery Indicator



No Power

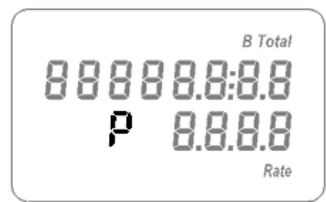

External Power Indicator



Empty Pipe



Battery Power

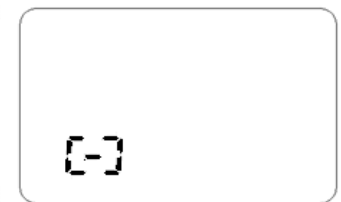

Meter Installed Backwards

OPTIONAL INPUTS, OUTPUTS and TROUBLESHOOTING

Optional Input and Outputs. An optional cable, factory-installed or field-installed by an authorized individual, provides power input, pulse output (for remote reading, 4-20 mA conversion, telemetry and data logging functions), and serial output (when preconfigured for technician use in custom telemetry applications). See diagram below. The factory-default pulse output rate is High Frequency*.

Detailed wiring diagrams provided with cable.

IMPORTANT: When field installing the input/output cable, be sure to snugly tighten the cable strain relief to prevent water ingress.

*See High Frequency Output Technical Bulletin

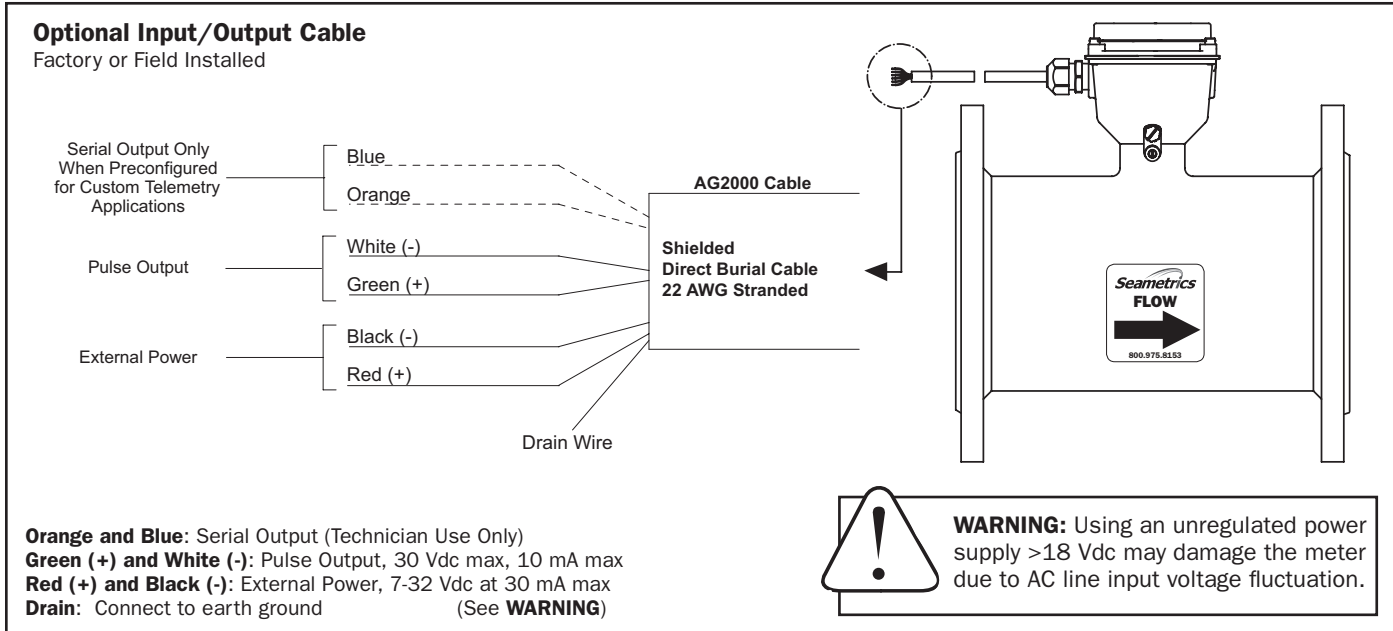

TROUBLESHOOTING

Problem	Probable Cause	Try...
Blank display	Dead battery	Replace battery pack
Flow rate steadily reads zero when there is flow	Flow is below cutoff (very low) There is air in the meter	Reading will resume when flow increases Reposition meter for full pipe
Display reads [-]	Meter is installed backward	Note flow direction arrow, reverse meter
Flow rate intermittently drops when there is flow	There is air in the meter	Reposition meter for full pipe or rotate to avoid bubbles
Jumpy reading	Improperly equalized Pulsing flow Rapidly changing conductivity (chemigation applications)	Check for proper equalization Use external power source (allows more flow averaging) Install chemigation line downstream of meter (or enough upstream for thorough mixing of fluids before meter)



Seametrics Incorporated • 19026 72nd Avenue South • Kent, Washington 98032 • USA
(P) 253.872.0284 • (F) 253.872.0285 • 1.800.975.8153 • www.Seametrics.com